



(12) **EUROPEAN PATENT SPECIFICATION**

(45) Date of publication and mention
of the grant of the patent:
29.07.1998 Bulletin 1998/31

(51) Int Cl.º: G06K 7/14, G06K 19/14,
G11B 7/00, G11B 7/24

(21) Application number: 93103828.5

(22) Date of filing: 10.03.1993

(54) **Optical card and device to read same**

Optische Karte und Gerät zum Lesen derselben

Carte optique et appareil pour la lecture de celle-ci

(84) Designated Contracting States:
DE ES FR GB IT NL

(30) Priority: 10.03.1992 JP 86407/92

(43) Date of publication of application:
15.09.1993 Bulletin 1993/37

(73) Proprietor: OMRON CORPORATION
Kyoto 616 (JP)

(72) Inventors:
• Tsuboi, Kazuo
Takatsuki-city, Osaka 569 (JP)

• Iguchi, Koji
Takatsuki-city, Osaka 569 (JP)

(74) Representative: Kahler, Kurt, Dipl.-Ing. et al
Patentanwälte
Kahler, Käck, Fiener et col.,
Vordere Anger 268
86899 Landsberg/Lech (DE)

(56) References cited:
EP-A- 0 374 256 WO-A-90/10916
GB-A- 2 228 821

• PATENT ABSTRACTS OF JAPAN vol. 13, no. 526
(M-897)22 November 1989 & JP-A-01 214 487.

EP 0 560 318 B1

Note: Within nine months from the publication of the mention of the grant of the European patent, any person may give notice to the European Patent Office of opposition to the European patent granted. Notice of opposition shall be filed in a written reasoned statement. It shall not be deemed to have been filed until the opposition fee has been paid. (Art. 99(1) European Patent Convention).

Description**FIELD OF THE INVENTION:**

This invention concerns an optical card on which data are optically recorded and reproduced and an optical card system.

BACKGROUND:

Figure 10 shows a relevant prior art optical card 101. Figure 9 shows the actual structure of such a card. In these figures 9 and 10, display symbols 3 constitute the logo and other information which is entered on a base layer 2. A light-absorbing printed layer 4, which consists of a paint having low reflectivity in the wavelength region of the light used to record and reproduce data, is painted onto the base layer 2. Layer 5, on which data are recorded optically, is laminated onto the light-absorbing printed layer 4 by means of film 6. Transparent layer 7 and protective layer 8 are laminated, in that order, so as to cover the entire surface of base layer 2. The prior art optical card 101 is thus completed.

To record data on the above-described optical card 101, a light beam is modulated in a manner corresponding to the symbols to be recorded. This light beam is trained on the recording layer 5, causing pitting on that layer.

To reproduce, or play back, the data from optical card 101, a light beam is aimed at the pits on recording layer 5. The light is diffracted by the pits, and the resulting modulated optical signals are detected by a photo-detector (not pictured).

Layer 5 on the prior art optical card 101 has a large recording surface. This makes it difficult to check the area where visible data, consisting of characters, images, and the like, are stored on the card. To address this problem, it has been suggested that visible data such as characters, images (a photo of the cardholder's face, etc.) and the like be entered on the back of optical card 101. However, this scheme leaves open the possibility that the data might be obliterated by being rubbed off and new data being forged in their place.

One solution to prevent forgery or alteration of the visible data would be to emboss this data on the surface of the optical card, thereby displaying such data as the identification number or the account number, as is done on standard credit cards or cash cards. However, this causes the card to have a non-uniform thickness, which makes it difficult for the card to be registered in the correct position in the recording and reproducing device.

Another solution is to record the identification number or account number image data on the recording layer 5, instead of that data being visible, so as to prevent forgery or alteration. However, this scheme results in the space available on layer 5 being substantially reduced. This is because the amount of space required, especially for image data, is prodigious. Furthermore, if

a reproducing device is not available there is no way to verify that image data stored on layer 5.

In WO 90/10916 an erasable optical data card is disclosed in which laser written data is recorded. The data card also contains permanently stored pre recorded information in form of surface contours or photograph marks. The pre recorded information is stored either a top or directly below the erasable recording strip.

10 SUMMARY OF THE INVENTION:

In view of the above-described problems associated with the prior art optical cards an objective of this invention is an optical card having a readily verifiable area where the visible character and image data are recorded. Another objective of this invention is an optical card resistant to forgery or alteration. A further objective is a device to reproduce the data on this card.

The present invention achieves the above objectives with an optical card according to claim 1. Human-readable data are printed on a light absorbing layer coated on the base layer and a transparent optical recording layer is formed on top of the light-absorbing layer and the human-readable data.

The optical card system of this invention is defined in claim 4.

BRIEF DESCRIPTION OF THE DRAWINGS:

Figure 1 is an oblique view illustrating the actual structure of the optical card of this invention.

Figure 2 is a cross section to show how the optical card in our example is actually constructed.

Figure 3 is a flat view showing the basic appearance of an example of the optical card of this invention.

Figure 4 is an oblique view showing the overall appearance of one example of the optical card system of this invention.

Figure 5 is a block diagram illustrating the actual structure of an optical card system in which this invention has been implemented.

Figure 6 is an oblique view of the overall appearance of another example of how the card system of this invention might be implemented.

Figure 7 shows the order of the processes involved in the manufacture and issuance of a sample optical card following the design of this invention.

Figure 8 is a continuation of the process shown in Figure 7.

Figure 9 is an oblique view showing the actual structure of a prior art optical card.

Figure 10 is a flat view showing the basic structure of a prior art optical card.

55 DETAILED DESCRIPTION OF THE INVENTION:

This section explains an embodiment of the present invention, with reference to Figures 1 through 3. Ele-

ments identical to those shown in the prior art Figure 9 are given the same numbers.

Figure 1 is an oblique view illustrating the actual structure of the optical card 1 of this embodiment. On this card 1, the visible data 9, which include such information as name, address and telephone number, are printed (and thus entered) on light-absorbing print layer 4. Recording layer 5, on which data will be recorded by, for example, the established method of forming pits for diffracting a light beam, is laminated via film 6 onto the light-absorbing print layer 4, on which visible data 9 have been printed. Transparent layer 7 and protective layer 8 are then laminated, in that order, in such a way as to cover the entire surface of base layer 2. The optical card 1 of this embodiment is formed.

Figure 2 is a cross section showing the structure of optical card 1. In this figure, visible data 9 are printed on light-absorbing print layer 4. Film 6 is attached to layer 4 by means of adhesive 11. Recording layer 5 is laminated on top of film 6. Transparent layer 7 and protective layer 8 are attached by means of adhesive 12.

Figure 3 is a flat view showing the basic appearance of the optical card 1. It shows examples of the visible data 9 printed on the card: name, phone number and signature. Data 9 could also include a photograph or other image data.

With an optical card 1 structured in this described manner, film 6 covers the light-absorbing print layer 4, where visible data 9 are printed: If someone attempts to peel off film 6 to forge or alter information, the recording layer 5 will be destroyed.

An example of the data reading device which reads the visible data printed on optical card 1, with reference to Figures 4 and 5 will now be described. A description of an optical data reading device which reads the non-visible data formed as pits in layer 5 is not presented, as it is identical to the light beam reader of prior art. In Figure 4, the data reader 21 has an image scanner 22 which optically reads the images in the visible data 9. When the data reader 21 moves in the direction indicated by the arrow, image scanner 22 begins to scan. The image data read by the image scanner 22 in the course of its scan are transmitted to printer 24 through transmission cable 23. The image data transmitted to the printer 24 are printed on document 25.

Figure 5 is a block diagram illustrating the actual structure of the data reader 21. As shown in that figure, optical beam emitter 31 outputs an optical beam. When data reader 21 moves in the direction shown by the arrow, the reader begins to scan in the specified direction. The optical beam is directed to the region where visible data 9 are printed on the optical card 1. The optical beam reflected by the optical card 1 passes through lens 32 and is directed to the optical beam detector 33. This detector 33 converts the light received into electrical signals corresponding to the quantity of light. These electrical signals are input into signal processing unit 34, where they are processed so as to increase the contrast

and remove the noise and are then binarized. These binarized signals are input into buffer 35, where they are temporarily stored. When buffer 35 accumulates one page worth of data, those data are input into printer 24 by way of printer drive unit 36 and data transmission cable 23.

It is possible to combine image scanner 22 and printer 24 in a single device, as shown in data reader 41 in Figure 6. In this way, the images within the printed visible data 9 can be printed on document 25. With this scheme, optical card 1 can be used to produce documents in the same way as embossed magnetic cards, such as credit cards, are used.

Visible data 9 may be printed in an ink whose reflectivity is virtually identical to that of light-absorbing print layer 4 with respect to light in the visible wavelength region, but which differs from print layer 4 in its reflective characteristics within wavelengths beyond the visible spectrum, such as infrared. Printing visible data 9 with such an ink will result in the printed data being essentially not visible to the eye; but the printed image data can be detected by a data reader which scans the image with an infrared beam. This feature allows the optical card to have the function served by the watermark on paper money, and makes the card further resistant to forgery.

The steps for producing a specific example card 82 of the optical card 1 will now be described, with reference to Figures 7 and 8. For this example, the produced card will be a credit card. As is shown in Figure 7 (a), card pattern 52, consisting of the shape of the card, the logo, and other information, and positioning marks 53 have already been printed on base layer 51, which is covered with a protective sheet 61. Sheet 61 has a hole 62 cut in it corresponding to the position where the signature, which will be one of the items in the visible data 9, will be placed. Protective sheet 61 has another protective sheet, 63, affixed so that it covers hole 62.

As can be seen in Figure 7 (b), the cardholder removes protective sheet 63 and signs his name with pen 54 on the light-absorbing print layer 4. This signature is then covered and preserved by the protective sheet 63. The cardholder then sends the base layer 51, which is also covered by the protective sheet 61, to the card manufacturing facility. At the manufacturing facility, the protective sheet 61 is removed from the base layer 51. The multilayer sheet 71, which will form the recording layer, is then applied to the base layer 51 in such a way that positioning marks 53 coincide with the positioning marks 73 (Figure 7 (c)). Multilayer sheet 71 consists of a recording layer 72, a transparent layer 73 and a protective layer 74, which correspond, respectively, to layers 5, 7, and 8 of the generic card shown in Figs. 1-3. In this way optical card assembly 81 is formed, as shown in Figure 7 (d).

Next, the optical card 82 is punched out along the indicated pattern, as shown in Figure 8 (a), and the card is completed. Figure 8 (b) is a flat view showing the ap-

pearance of the completed optical card 82. Except for signature 91, all the visible data, i.e., trademark 93 and identification number 92, were printed as light-absorbing print layer 4 on base layer 51.

As was discussed above, the optical card described in this application is a card on which data can be recorded and reproduced optically. Visible data are entered on the base layer of this card, and an optically transparent recording layer, for recording nonvisible data, is formed above these visible data. This allows the region where the data, consisting of characters, images, or the like, are stored to be visually checked, and serves to prevent forgery or alteration of the data.

The foregoing description of this invention is given in terms of the specific embodiments described herein. However, upon reading this disclosure adaptation, variations and modifications within the scope of this invention as defined by the claims will become readily apparent to one of ordinary skill in the art.

Claims

1. An optical card for recording and reproducing optical data, comprising:
 - a base layer (2; 51);
 - a light-absorbing layer (4) coated on said base layer (2; 51) and
 - a substantially transparent recording layer (5; 72) having means for storing optical data, formed on top of said light absorbing layer (4),
 characterized in that
 - human-readable data (9; 92, 93) are printed on said light-absorbing layer (4), which human readable data (9; 92, 93) are covered by said recording layer (5; 72).
2. An optical card for recording and reproducing optical data according to claim 1,
 - wherein said human-readable data (9; 92, 93) are visible.
3. An optical card for recording and reproducing optical data according to claim 1 or 2,
 - wherein said human-readable data (9; 92, 93) are marked by an invisible ink having a reflectivity virtually identical to the reflectivity of said light-absorbing layer (4) in a visible wavelength light, and
 - wherein said invisible ink has reflective characteristics differing from the reflectivity of said light-absorbing layer (4) in an invisible wavelength light, so that said human-readable data (9; 92, 93) can be detected by a light within said invisible wavelength.

4. An optical card system comprising:
 - an optical card (1; 82) as defined in any one of the claims 1 to 3, and
 - an optical card reader (21, 41), having means for scanning said human-readable data (9; 92, 93) and generating binary data corresponding thereto.

Patentansprüche

1. Optische Karte zum Aufzeichnen und Wiedergeben von optischen Daten, welche umfaßt:
 - eine Grundschrift (2; 51);
 - eine lichtabsorbierende Schicht (4), die auf die Grundschrift (2; 51) aufgetragen ist, und
 - eine im wesentlichen transparente Aufzeichnungsschicht (5; 72) mit Mitteln zum Speichern optischer Daten, die auf der lichtabsorbierenden Schicht (4) ausgebildet ist,
 dadurch gekennzeichnet, daß
 - für den Menschen lesbare Daten (9; 92, 93) auf die lichtabsorbierende Schicht (4) gedruckt sind, wobei die für den Menschen lesbaren Daten (9; 92, 93) von der Aufzeichnungsschicht (5; 72) bedeckt sind.
2. Optische Karte zum Aufzeichnen und Wiedergeben von optischen Daten nach Anspruch 1,
 - wobei die für den Menschen lesbaren Daten (9; 92, 93) sichtbar sind.
3. Optische Karte zum Aufzeichnen und Wiedergeben von optischen Daten nach Anspruch 1 oder 2,
 - wobei die für den Menschen lesbaren Daten (9; 92, 93) mit einer unsichtbaren Tinte markiert sind, die ein Reflexionsvermögen aufweist, das dem Reflexionsvermögen der lichtabsorbierenden Schicht (4) im Licht einer sichtbaren Wellenlänge virtuell identisch ist, und
 - wobei die unsichtbare Tinte Reflexionseigenschaften aufweist, die sich vom Reflexionsvermögen der lichtabsorbierenden Schicht (4) im Licht einer unsichtbaren Wellenlänge unterscheiden, so daß die für den Menschen lesbaren Daten (9; 92, 93) durch ein Licht innerhalb des unsichtbaren Wellenlängenbereichs erfaßt werden können.
4. System für eine optische Karte, welches umfaßt:
 - eine optische Karte (1; 82) nach einem der Ansprüche 1 bis 3, und
 - ein Lesegerät (21, 41) für eine optische Karte

mit Mitteln zum Abtasten der für den Menschen lesbaren Daten (9; 92, 93) und zum Erzeugen von binären Daten, die diesen entsprechen.

données binaires correspondant à celles-ci.

Revendications

1. Carte optique pour enregistrer et reproduire des données optiques, comprenant :
- une couche de base (2 ; 51);
 - une couche absorbant la lumière (4) appliquée sur ladite couche de base (2 ; 51);
 - une couche d'enregistrement essentiellement transparente (5 ; 72) présentant des moyens destinés à stocker des données optiques, formée sur le dessus de ladite couche absorbant la lumière (4);
- caractérisée en ce que
- des données lisibles par l'homme (9, 92, 93) sont imprimées sur ladite couche absorbant la lumière (4), lesdites données lisibles par l'homme (9 ; 92, 93) étant recouvertes par ladite couche d'enregistrement (5 ; 72).
2. Carte optique pour enregistrer et à reproduire des données optiques selon la revendication 1, dans laquelle lesdites données lisibles par l'homme (9 ; 92, 93) sont visibles.
3. Carte optique pour enregistrer et à reproduire des données optiques selon la revendication 1 ou 2, dans laquelle lesdites données lisibles par l'homme (9 ; 92, 93) sont marquées par une encre invisible présentant un pouvoir de réflexion essentiellement identique au pouvoir de réflexion de ladite couche absorbant la lumière (4) dans une lumière à longueur d'onde visible, et dans laquelle ladite encre invisible présente des caractéristiques réfléchives différent du pouvoir de réflexion de ladite couche absorbant la lumière (4) dans une lumière à longueur d'onde invisible, de sorte que les données lisibles par l'homme (9 ; 92, 93) peuvent être détectées par une lumière à l'intérieur de ladite longueur d'onde invisible.
4. Système de carte optique comprenant :
- une carte optique (1 ; 82) selon l'une des revendications 1 à 3, et
 - un lecteur de carte optique (21, 41) présentant des moyens pour scanner lesdites données lisibles par l'homme (9 ; 92, 93) et générer des

FIGURE 1

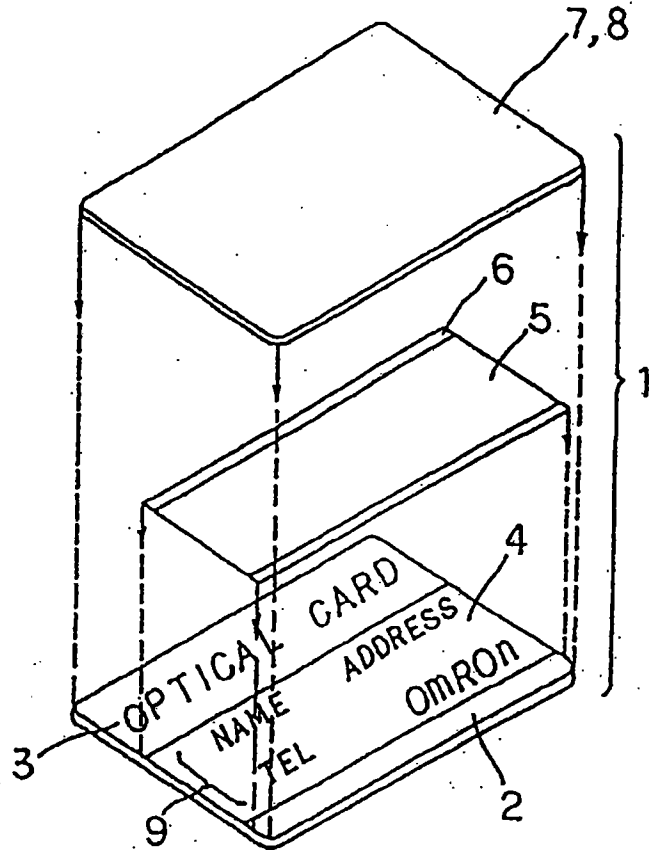

FIGURE 3

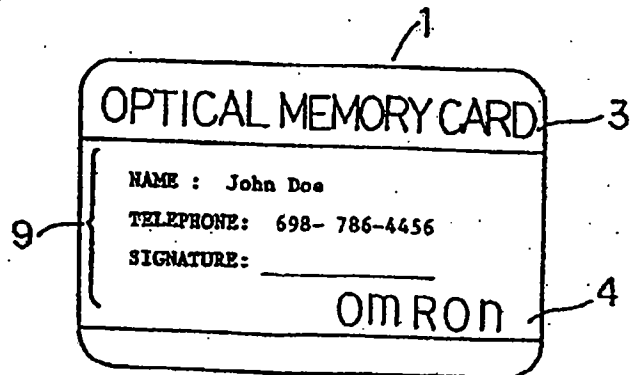

FIGURE 2

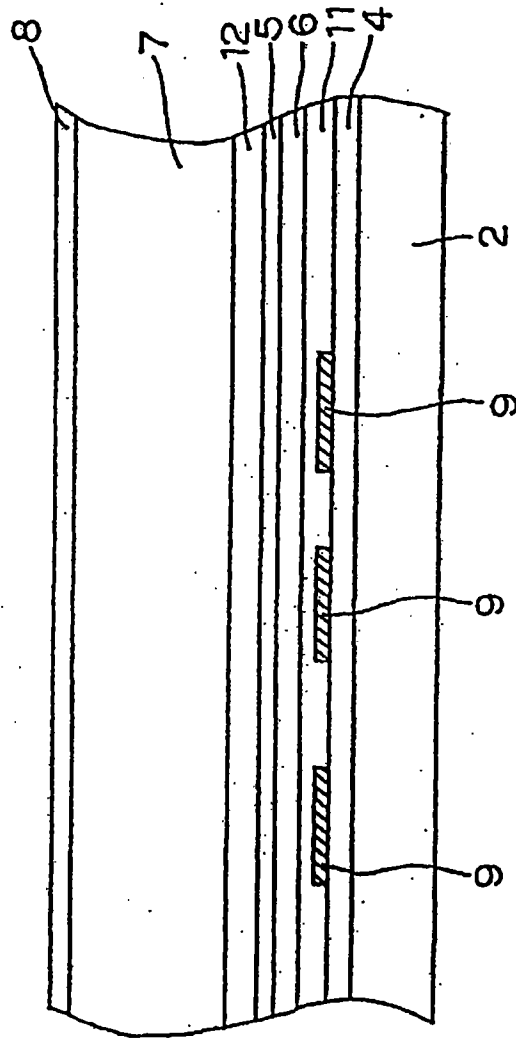

FIGURE 4

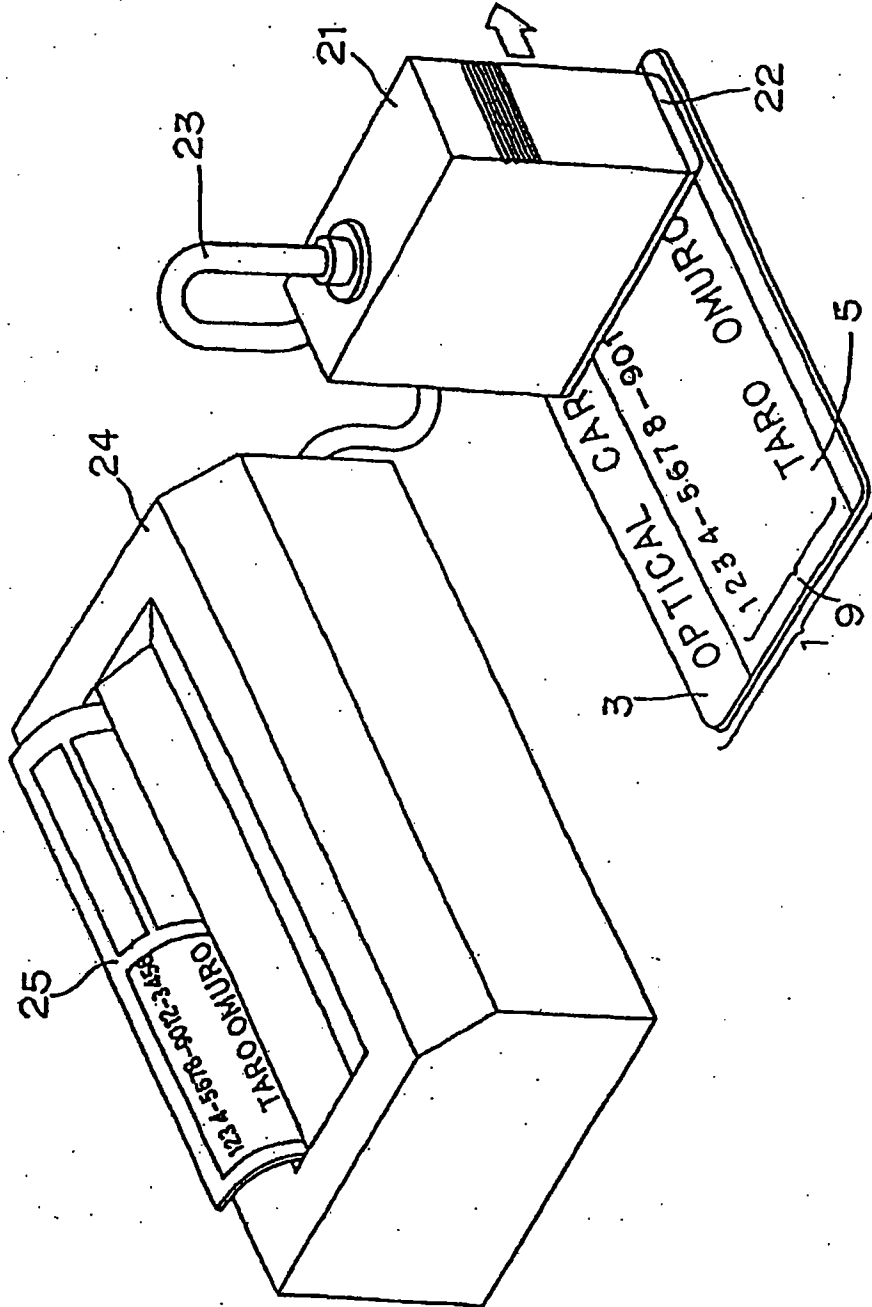

FIGURE 5

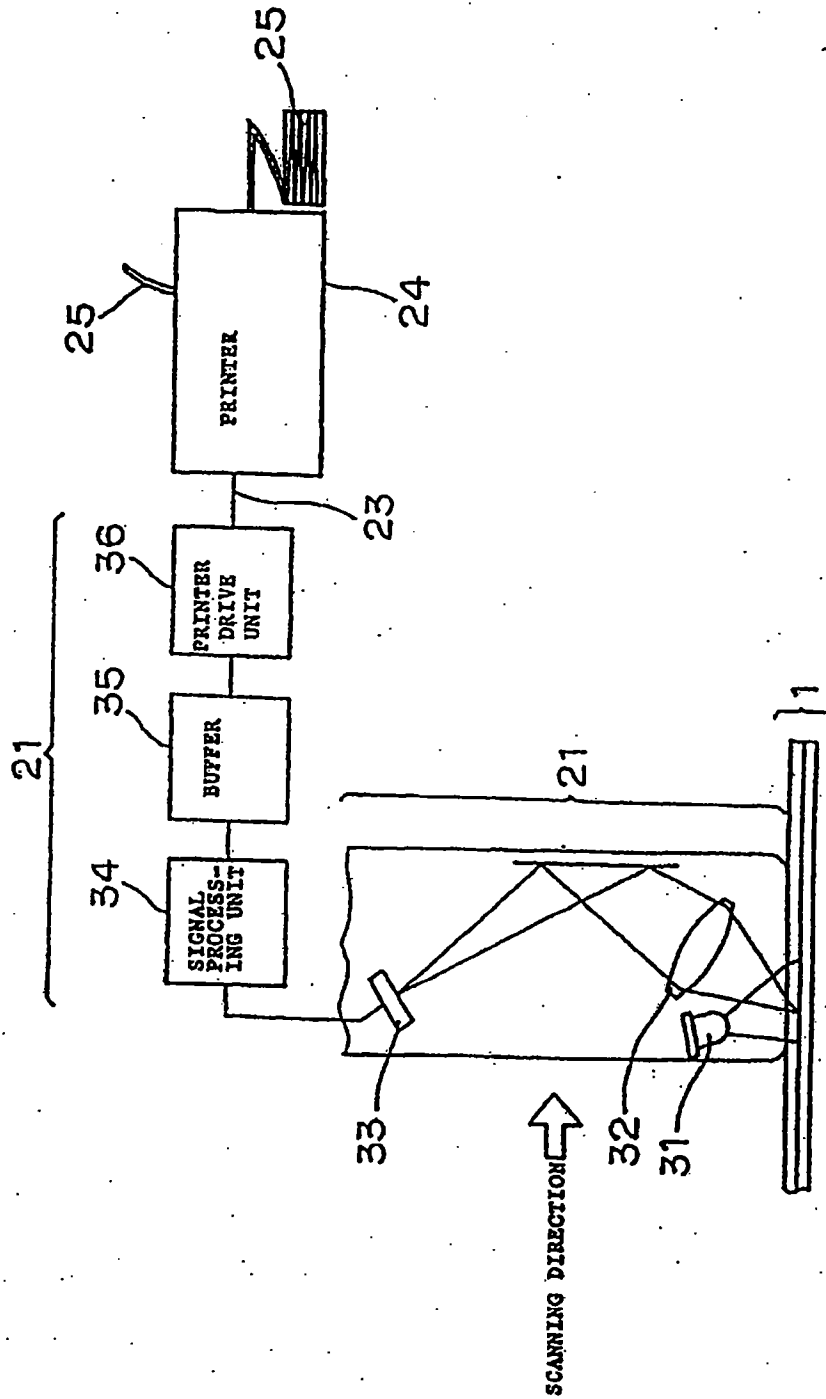
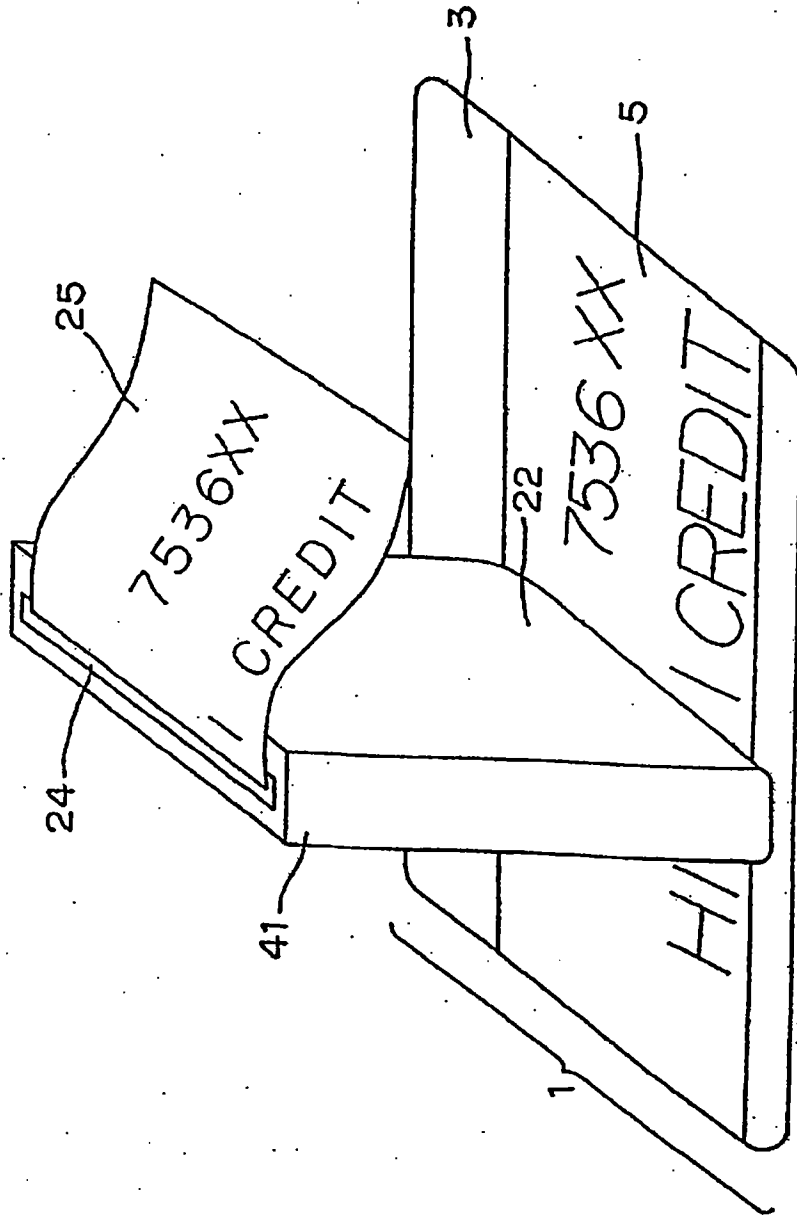

FIGURE 6



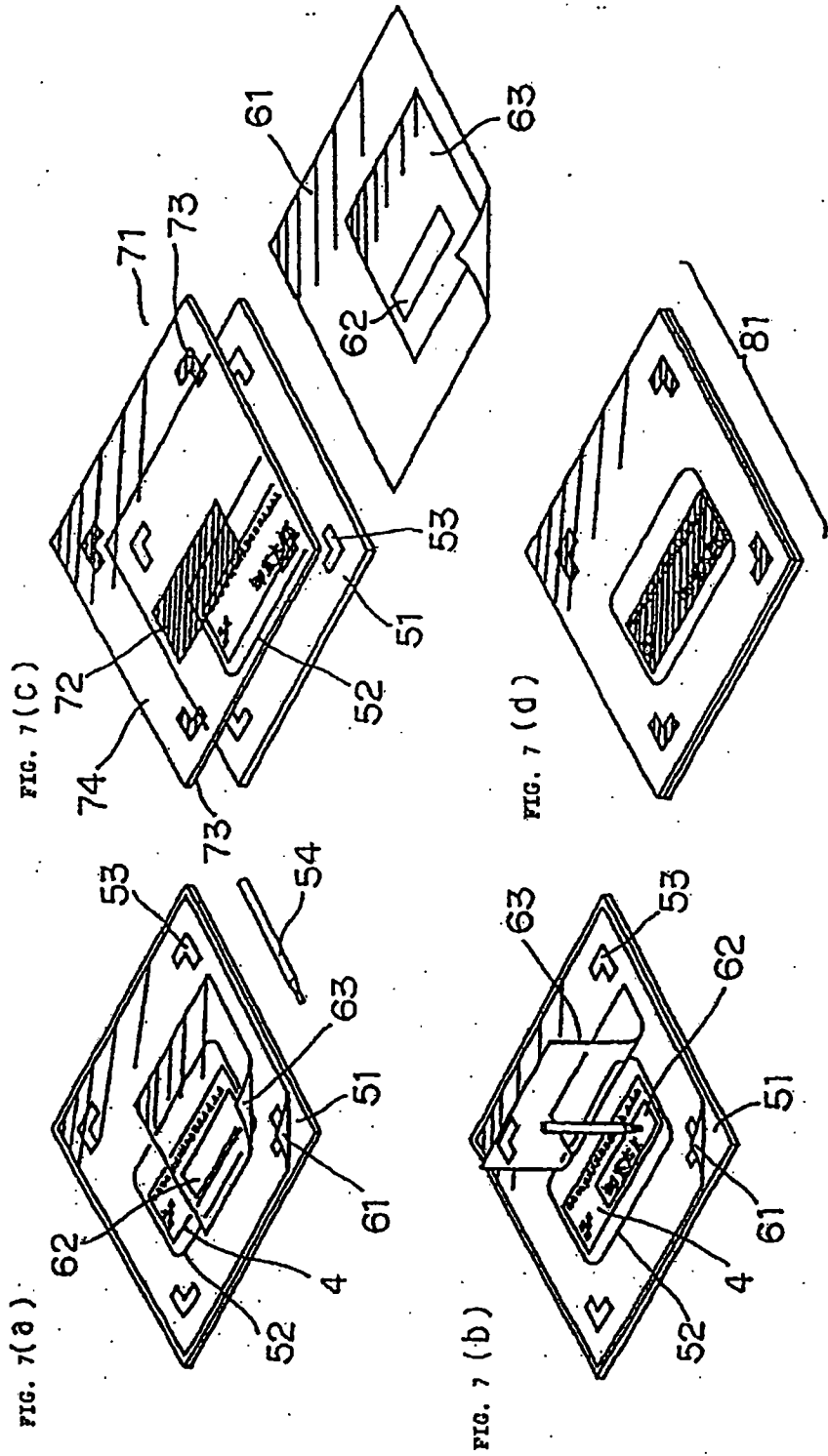

FIG. 8(a)

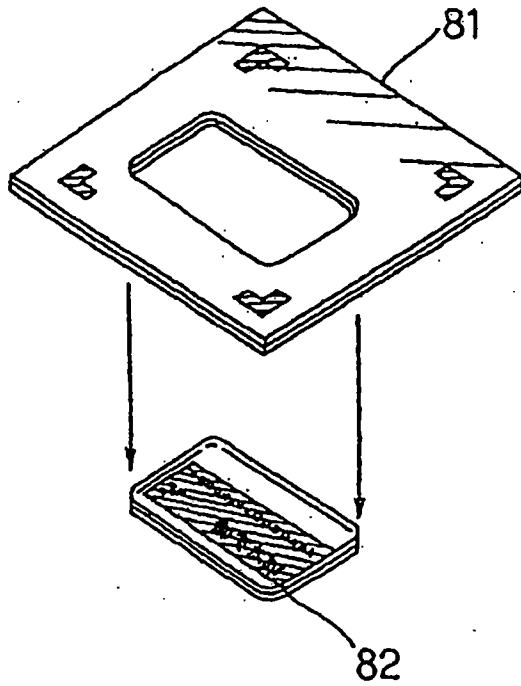

FIG. 8(b)

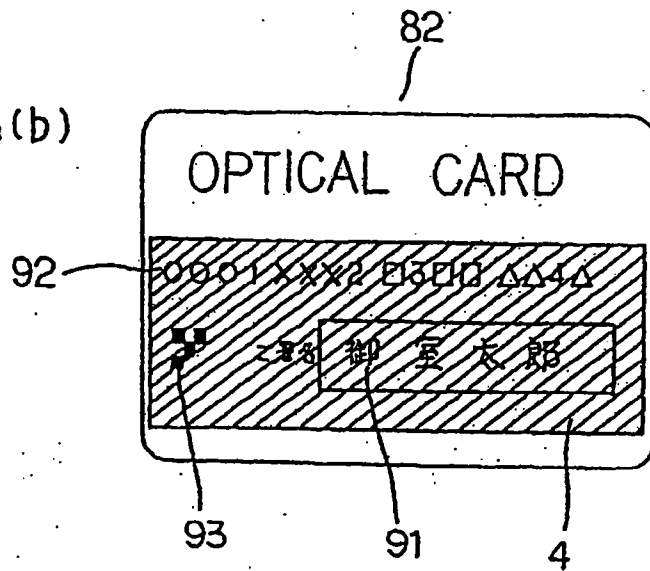

Figure 9
Prior Art

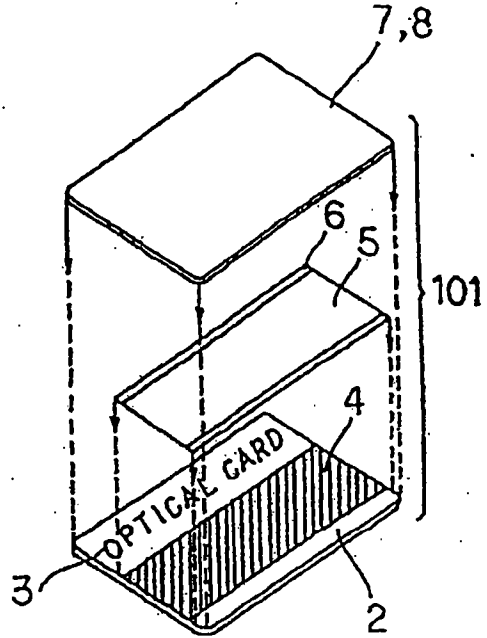

Figure 10
Prior Art

